

AKM 105, 115: Rotary drive for ball valve

How energy efficiency is improved

Torque-dependent cut-off for efficient energy use.

Areas of application

For actuating 2-way and 3-way ball valves in the VKR and BKR series. For controllers with a switching output (2/3-point control).

Features

- Synchronous motor with control and electronic cut-off
- Electronic end position detection and motor cut-off with time switch in the device
- Maintenance-free gearbox with magnetic clutch
- Gearbox that can be disengaged for positioning the ball valve manually (with hand lever)
- Assembly with ball valve without any tools

Technical description

- Two-part housing made of self-extinguishing plastic, lower section black, upper section yellow
- Console and bayonet ring made of glass-fibre-reinforced plastic for fitting onto ball valve
- Connecting cable 1.2 m long, 3 x 0.75 mm²
- Depending on the model, the running time for 90° rotation angle is 30 or 120 secs
- Installation position: vertically to horizontally, but not upside down



T10642



Y07551

Type	Control	Running time s	Rotation angle	Voltage	Weight kg
AKM 105 F100	2/3-point	30	90°	230 V~	0,7
AKM 115 F120	2/3-point	120	90°	230 V~	0,7
AKM 115 F122	2/3-point	120	90°	24 V~	0,7

Supply voltage	230 V~ ± 15%, 50 to 60 Hz 24 V~ ± 20%, 50 to 60 Hz	Protection class (horizontal) Protection class	IP 54 acc. to EN 60529 ³⁾ III acc. to IEC 60730 II acc. to IEC 60730
Power consumption		Min. response time	200 ms
F100	2,4 W 4,5 VA	Connection diagram	2-point A10464 3-point A10463 Dimension drawing M10489
F120	2,0 W 4,0 VA		
F122	1,6 W 1,7 VA		
Max. medium temperature ²⁾	100 °C	Fitting instructions	P100001578
Perm. ambient temperature	-10...55 °C	Declaration on materials and the environment	MD 51.363
Perm. ambient humidity	5...95% rh without condensation		

Accessories

- 0372459 100*** External circuit 230V Version for parallel operation with A . M 1 . 4 or drives with limit switches incl. distribution socket; MV 506102
- 0372459 102*** External circuit 24V Version for parallel operation with A . M 1 . 4 or drives with limit switches incl. distribution socket; MV 506102
- 0510420 001*** Temperature adapter required at >100 °C Medium temperature for VKR / BKR (recommended at a temperature of <10 °C); P100002660
- 0510480 001*** Auxiliary change-over switch ¹⁾ single; P100002035
- 0510480 002*** Auxiliary change-over switch ¹⁾ double; P100002035

*) Dimension drawing or connection diagram available under same number

- 1) Infinitely adjustable 0...100%, perm. load 5(2) A, 24 to 230 V
 2) For medium temperature > 100 °C use appropriate accessory
 3) See Fitting instructions P100001578

Function

Applying the voltage via the cable causes the final control element that is being operated to be moved to any arbitrary position by the driver axle.

Sense of rotation with 3-point control (when viewed from drive to ball valve spindle):

- axle rotates anti-clockwise, with voltage applied to brown cable, and the through branch of the ball valve is opened.
- axle rotates clockwise, with voltage applied to black cable, and the through branch of the ball valve is closed.

Change of rotating direction with 3-point control by swapping the connections

Sense of rotation with 2-point control (when viewed from drive to ball valve spindle):

The black cable is always live.

- axle rotates anti-clockwise, with voltage applied to brown cable, ball valve is opened.
- axle rotates clockwise, with no voltage applied to brown cable, ball valve is closed.

In the final positions (stop in drive) or in the event of an overload the magnetic clutch is activated. The actuation signal is switched off by the shut-off electronics after 3 minutes or 60 seconds (F100).

Manual adjustment takes place by disengaging the gearbox (slide switch next to connecting cable) and simultaneous rotation using the manual adjusting lever. The drive position is indicated by the manual adjusting lever or the indicator knob on the upper part of the drive.

Attention: return slide switch after making manual adjustment (engage gearbox).

Engineering and fitting notes

Condensation, drip water etc. must be prevented from penetrating the drive along the carrier axle. A suspended location (overhead installation) is not permitted.

The drive / ball valve are installed by fitting them and rotating the bayonet ring as far as it will go without any further adjustment. No tools are required. The spindle of the ball valve and the driver axle are connected automatically, either by means of manual adjustment and moving to 100% stroke or by applying the voltage to terminal MM/N and 01. Dismantling is carried out by simply opening the bayonet ring and removing the drive. The delivery setting is the centre position.

A synchronous motor used with a magnetic coupling enables several rotary drives of type AKM (with accessory 0372459 10 . only) to be connected electrically in parallel.

If a potentiometer is needed, the accessories of AVM 105, 115 can be used but the control action on the name plate is the wrong way round. The maximum number of accessories that can be used for a drive is 1 auxiliary change-over switch or 1 potentiometer.

The auxiliary switch accessory is screwed to the top cover of the drive. The indicator knob must be removed to make the mechanical connection. A new indicator can be seen on the cover of the accessory.

Attention! The housing must not be opened.

Fitting outdoors. It is advisable to protect the devices from the effects of the weather if they are installed outdoors.

Additional technical tasks

The upper part of the housing with cover and indicator knob contains the synchronous motor with capacitor and electronics for switching off. The lower part of the housing contains the maintenance-free gearbox and the gearbox disengaging knob.

Auxiliary change-over switch

Switching capacity max. 230 V~, current min. 20 mA at 20 V

Switching capacity max. 4 to 30 V=, current 1 to 100 mA

Power consumption:

Type	Running time s	Condition	active power P W	apparent power S VA
AKM 105 F100	30	Operation	2,4	4,5
AKM 115 F120	120	Operation	2,0	4,0
AKM 115 F122	120	Operation	1,6	1,7

CE conformity

EMC Directive 2004/108/EC

EN 61000-6-1

EN 61000-6-2

EN 61000-6-3

EN 61000-6-4

Low Voltage Directive 2006/95/EC

EN 60730-1

EN 60730-2-14

Overvoltage category III

Pollution level II

Connection diagram

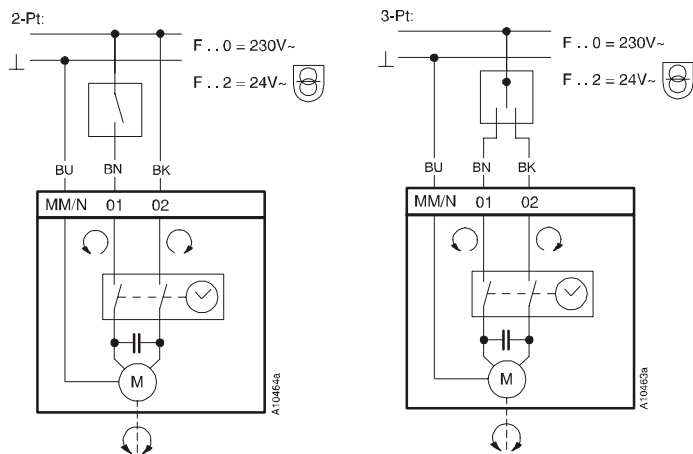

Dimension drawing

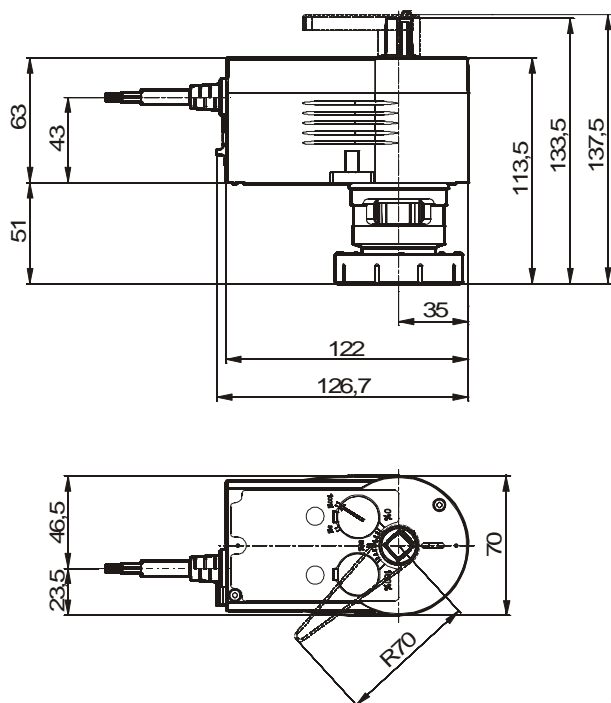

Accessories

510480 001

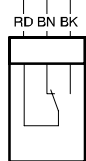

A09782

RD = red
BN = brown
BK = black

510480 002

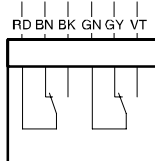

A10183

372459 10 .

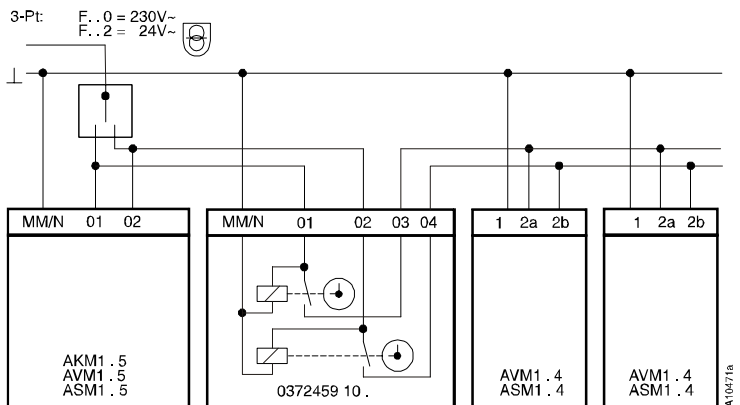
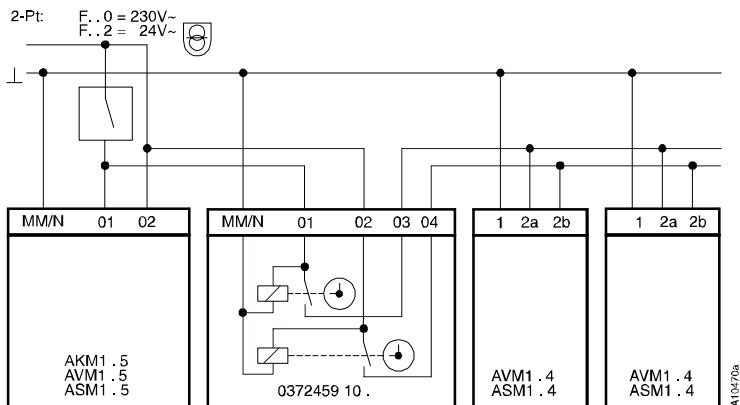

0510420 001

